



Job Shop Machining Services

Designer, Manufacturer and Integrator of Machines and Tooling



- **Machine to Print**
- **Short and Medium Run Production**
- **Prototyping**
- **Gages and Fixtures**
- **Contract Manufacturing**
- **Managed Inventory**

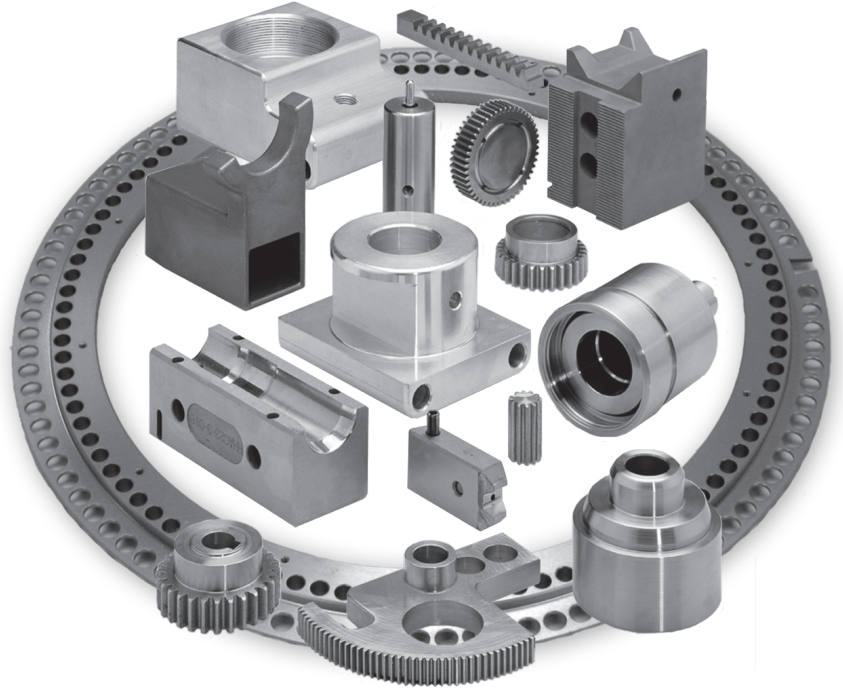

Lomar machining services utilize the latest in CNC lathes, horizontal and vertical machining centers, grinding equipment and EDM machines.

Parts can be machined out of a variety of materials such as plastics, aluminum, mild steel, tool steel, brass, bronze, and stainless steel.

Depending upon your application, several material finishing processes are available including special heat treating (including ion nitride), electroplating, passivating, and anodizing.



Tool & Die makers possess the knowledge and experience to produce the high quality, precision products our customers rely on.

Equipment List

- (2) CNC 5-Axis Vertical Machining Center: 40" x 25" x 25"
- (1) CNC 3-Axis Vertical Machining Center, 30" X 16" X 20", equipped with a 5 axis attachment.
- (16) CNC Vertical Machining Centers with up to 120" X, 40"Y, 30"Z Travel, with up to 30 Position Automatic Tool Changers, and Programmable Rotary 4th Axis Attachments and Probe Systems.
- (12) Vertical mills retrofitted with 2-Axis CNC Controls.
- (1) Horizontal Machining Center, 22" X 25" X 22" with 6-station pallet pool.
- (1) Horizontal Machining Center, 28.7 X 28.7 X 31.5 with pallet station.
- (1) Horizontal Machining Center, 64x50x32 with 30 inch dia 4th axis platter.
- (2) Horizontal Mills Retrofitted with 2-Axis CNC Controls.
- (16) CNC Lathes with Capacities to 24" Dia. X 40" Lg., up to 29 H.P.
- (2) CNC Lathes with Capacity to 2" Dia. X 40" Long with Bar Feeder (1 - Dual Spindle with bar feed)
- (10) Engine Lathes to 19" O.D. x 72" Long., All with D.R.O.
- (4) High Speed Second Operation Lathes.
- (3) Wire E.D.M. Machines. 19.69" X, 13.77" Y, 11.81" Z.
- (3) Plunge Type E.D.M. Machine. 12" X 12" X 16" - 29 Tool Changer - Rotary "B" Axis.
- (1) E.D.M. Drill Machine.
- (6) Surface Grinders with Capacities to 20" by 40".
- (2) Blanchard Grinders, 36" & 42".
- (4) Cylindrical Grinders with Capacities to 6" O.D. X 120" Long.
- (3) CNC I.D. / O.D. Grinder, 12" X 20".
- (2) Thread Grinders, up to 6" Dia. by 18" Long. Standard, Metric and UNJ threads.
- (1) Barber-Coleman Helical Hob Grinder.
- (2) Honing Machines, Including I.D. and O.D.
- (1) CNC Horizontal Milling Machine, 28" X 28" X 31" 1 Degree Index Table, 60 Tool Magazine & Pallet Changer.
- (1) Vertical Milling Machine.
- (2) Lee Bradiner Spline Hobbers to 6" O.D. X 120" Long.
- (6) Cutoff Saws with Capacity to 18."
- (1) Moore #3 jig grinder.
- Many Drill Presses, Pedestal Grinders, Belt and Disk Sanders.
- Hydraulic and Arbor Type Presses with Capacity to 50 Tons.
- (4) Heat Treat Furnaces, Tempering Ovens, Including Controlled Atmosphere, Circulating Oil Quench Tank.
- (2) Cabinet Type Sandblaster.
- CNC Machines Supported with MASTERCAM.
- (1) Laser Marking Machine.

3D Printing Services

- (1) Markforged X3 (330mm X 270mm X 200mm)
- (1) Markforged Mark 2 (320mm X 132mm X 154mm)
- (1) Markforged Onyx One (320mm X 132 X 154mm)
- (1) Makerbot Replicator (295 X 195mm X 165mm)



135 Main Street
Horton, MI 49246 U.S.A.
Phone: (517) 563-8136
email: sales@lomar.com
www.lomar.com



Quality Assurance

- (1) Keyence IM-Series Instant Measurement System
- (3) Brown & Sharp Coordinate Measuring Machine (Microval/Minstral)
- 13" Mitutoyo Height Master.
- (3) 16" Optical Comparator with Edge Detection and D.R.O. and Video Inspection Machine.
- (2) Rockwell Hardness Testers.

All Quality Assurance Instruments are Traceable to N.I.S.T.

ISO 9001: 2015



65,000 square climate controlled facility helps ensure consistency in manufacturing processes.